

Roof Slate Westerland

fibre cement slate with dressed edge and textured surface





Westerland slate

Cembrit manufacturing plants have been developing and supplying roofing products, including slates for over 90 years.

Cembrit prides itself on manufacturing fibre cement slates which achieve the highest approvals from local, national and international agencies in the fields of product quality and sustainability.

Cembrit fibre cement slates are complemented by a range of fibre cement ridges, allowing compliance with the latest codes of practise for pitched roofing and condensation control. Cembrit slates and ridges can be found on all types of roofs across the British Isles.

Information on the complete Cembrit range appears on our website www.cembrit.co.uk

Environment

Environmental Management

Westerland slates are manufactured in a factory which complies with the requirements of BS EN ISO 14001: 2004. Find the current certificate on cembrit.co.uk.

Environmental Impact - European EPD EN15804

Following an LCA by the European Institute for Construction and Environment (IBU) an environmental product declaration (EPD) complying with ISO 14025 has been compiled by the IBU. To see the results in each of the impact categories find the certificate on cembrit.com/downloads.



Composition

Westerland slate has an appearance close to that of natural slate. Its attractive riven surface and randomly dressed edges make it an ideal solution for situations where a traditional appearance is important. It is manufactured to the highest European standards and is lightweight, pre-holed, suitable for all types of projects, easy to handle and install, durable and an economic alternative to natural roofing materials. Westerland slates are manufactured using Portland cement together with a non-asbestos formulation of superior blended synthetic and cellulose fibres. Westerland slates are pigmented during production and are fully compressed. They are finished with a high quality, semi-matt acrylic coloured coating to the top face and edges and a tinted, high performance binder to the back face.

Appearance

Westerland slates are available in 600 x 300mm format, in 3 colours, with a dressed edge and textured surface.



Welsh Blue



Blue Black



Graphite

Quality assurance

Westerland slates are manufactured in accordance with a quality assurance system to BS EN ISO 9001 and to the requirements of EN492:2012+A1:2016 product specification for fibre cement slates and their fittings. Westerland slate has been awarded the BBA Certificate No. 03/4041. The slates have been tested by Birmingham City Council Laboratories and approved for use on Birmingham City Council projects. They are accepted for use by many other local authorities.

Performance

Compatibility

Westerland slates are compatible with most common building materials, except those vulnerable to alkaline attack. When materials such as aluminium are used as flashings or gutters they should be protected and maintained with bituminous paint if they will be subject to water run-off from the slates.

Tolerances

Westerland slates are made to the following dimensional tolerances in accordance with BS EN 492: 2012.

Length or width: $\pm 3.0\text{mm}$ Thickness: $4\text{mm} + 1.0\text{mm}, - 0.4\text{mm}$

Mechanical characteristics

Average bending moment 45 Newton metres per metre.

Density

Westerland slates have an average density of 1850 kg/m^3 when tested to BS EN 492: 2012 section 7.3.1.

Fire

When tested according to BS EN13501-1 of A2 - s1, d0, as specified in BS EN 492:2012 Section 5.5 Fire Safety.

Durability

Westerland slates show satisfactory performance for the various requirements of BS EN 492:2012 section 5.4.

Thermal

The coefficient of linear expansion of Westerland slates is approximately $8 \times 10^{-6} \text{ mm/}^\circ\text{C}$. This is equivalent to an expansion of 0.08mm/m for a 10°C temperature change. Thermal conductivity (k value) is $0.35\text{W/m}^\circ\text{C}$.

Effects of chemicals

During tests Westerland slates have been found to have a good resistance to chemical attack, however it should be noted that prolonged exposure will cause surface degradation. In areas where this may be excessive please consult Cembrit Ltd for further advice.

Biological

Westerland slates are vermin and rot proof. The acrylic coating of the slates will reduce the potential growth of moss and lichen.

General design considerations

Westerland slates laid to BS 5534 will meet the strength requirements for the imposed and uniformly distributed wind and snow loads etc. The site exposure rating and the pitch of roof rafters will determine the size, pattern, lap and fixings for the slates. For UK and Northern Ireland locations, the latest version of BS 5534 will indicate the expected degree of exposure. Wind driven rain ratings less than 56.5 l/m² per spell are described as 'moderate' (see table 1) and those above 56.5 l/m² per spell are described as 'severe' (see table 2). Detailed guidance on wind load calculations is given in the latest versions of BS 5534: and BS EN 1991-1-4:2005 and 1991-1-3:2003 to calculate the wind action (design and snow loads) on a roof it will be necessary for the designer to use two documents at the same time; the Eurocode standard BS EN 1991 Part 1-4, and the associated National Annex. The authors of the National Annex have advised that reference should also be made to PD 6688-1:2011. In locations where abnormal conditions may be anticipated such as elevated sites, coastal locations, areas of heavy snowfall etc., the recommendation for 'severe' should be followed. For buildings above 12m in height, the influence of increased windspeed can be determined using BS EN 1991-1-4.

Where the location or construction might make a lower rafter pitch acceptable, designers are asked to seek advice.

Table 1 Moderate exposure

less than 56.5 l/m² per spell

- In general, the recommendations below apply to rafter lengths of not more than 9m. The specifier should also take account of any abnormal local conditions that might apply.

Pitch deg	Slate Size mm x mm	Minimum headlap mm	Slates no/m ²	Batten gauge mm	Average weight kg/m ²
45°	600 x 300	90	13.07	255	19.61
40°	600 x 300	90	13.07	255	19.61
35°	600 x 300	90	13.07	255	19.61
30°	600 x 300	90	13.07	255	19.61
27.5°	600 x 300	100	13.33	250	20.00
25°	600 x 300	100	13.33	250	20.00
22.5°	600 x 300	100	13.33	250	20.00
20°	600 x 300	110	13.61	245	20.41

An allowance should be made for cutting and wastage for all exposures.

Table 2 Severe exposure

greater than or equal to 56.5 l/m² per spell

- In general, the recommendations below apply to rafter lengths of not more than 6m. The specifier should also take account of any abnormal local conditions that might apply.

Pitch deg	Slate Size mm x mm	Minimum headlap mm	Slates no/m ²	Batten gauge mm	Average weight kg/m ²
45°	600 x 300	90	13.07	255	19.61
40°	600 x 300	90	13.07	255	19.61
35°	600 x 300	90	13.07	255	19.61
30°	600 x 300	100	13.33	250	20.00
27.5°	600 x 300	100	13.33	250	20.00
25°	600 x 300	110	13.61	245	20.41
22.5°	600 x 300	110	13.61	245	20.41
20°	600 x 300	110	13.61	245	20.41

Table 3 Technical specification

Size mm	Holed mm	Weight per 1000 kg	No. per Pallet	Colour
600 x 300	90-110 lap	1500	1000	Blue Black
600 x 300	90-110 lap	1500	1000	Graphite
600 x 300	90-110 lap	1500	1000	Welsh Blue

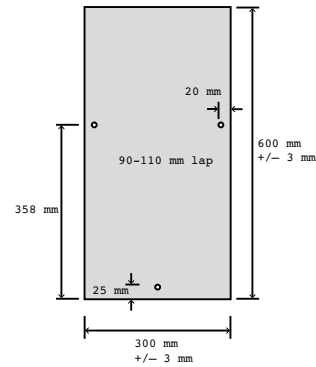

Sitework

Storage and handling

Westerland slates should not be allowed to become wet during storage as this may cause efflorescence staining as a result of water accumulating between the slates surfaces. If stored outside for short periods, the polythene hood should be removed and the slates open stacked and covered with a tarpaulin. The slates should be carefully stacked on their longer edges with timber bearers, battens or boards between layers. The lowest layer must be arranged on a firm level base.

Working

Westerland slates can be cut using the traditional method of scribing and breaking over a straight edge. Angle grinders are not recommended due to nuisance dust levels. Additional fixing holes should be drilled using a 4.5mm drill bit. Holes should not be less than 20mm from the edge of the slate. After cutting or drilling remove all dust from the slate to avoid possible staining.

Fixing

Westerland slates must be laid in accordance with the latest Code of Practice for Slating and Tiling, BS 5534: 2014, and the Code of Practice for Workmanship on Building Sites - Slating and Tiling, BS 8000: Part 6: 2013. The roof structure should be checked to ensure that it is to a true line and squareness tolerance, and set out to ensure that:

- the minimum cutting of slates is necessary.
- the long edges of the slates are parallel to the direction at which the water will run off the roof. In some instances this may result in raking cuts to all the eaves and the ridges.
- the horizontal lines of the courses are straight and true.
- the perpendicular lines of the slate are to a true alignment and allow for a small 'perp' gap between slates (3mm \pm 1mm).

The last two items are best achieved using a chalked line.

The method of fixing is to centre nail each slate with two 2.65mm x 30mm long copper nails and secure the tail of the slate with a copper disc rivet of suitable quality (0.45 x \varnothing 20mm base with a 20 x \varnothing 2mm pin) correctly bent down-slope through 90°.

Slate and a half and double slate sizes should be drilled to accept three nails and two disc rivets as well as fixing holes for the slates in the course above. At all verges and abutments, alternate slate courses must start with slate and half width to maintain bond. Slate and a half widths must be used if the half slate is less than 150mm wide. At valleys and hips where slates need to be cut on the rake, wide slates must be used to maintain an adequate width at the head or tail. At mitred hips on low pitched roofs wide slates should be used beneath the hip capping.

Accessories

Cembrit dry fix fibre cement ridges are available in various profiles and pitch angles. Manufactured to BS EN 492:2012, in a factory operating ISO 9001 and 14001 quality and environmental management systems, their incorporation in your design will allow you to comply with current best practise.

For fibre cement ridges use 75mm long stainless steel Torx TX25 raised countersunk head.



Fibre-cement Ridge Fixing Locations

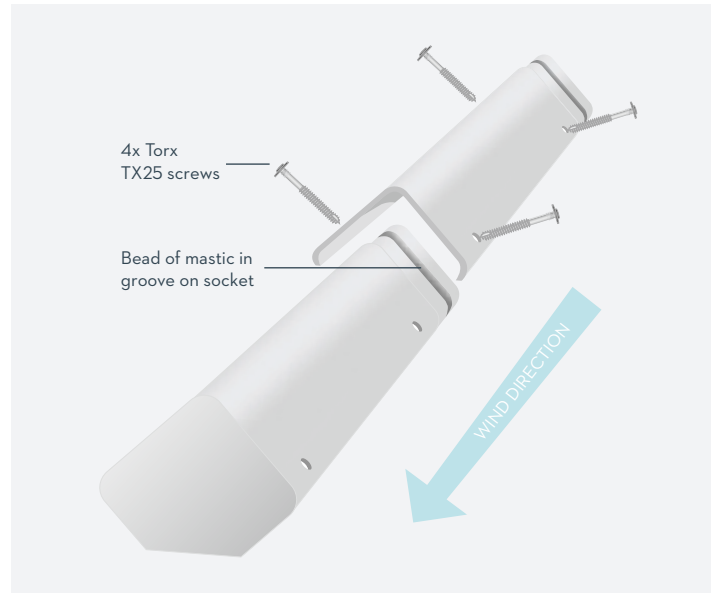

Continuously ventilated/Universal/plain angle ridge

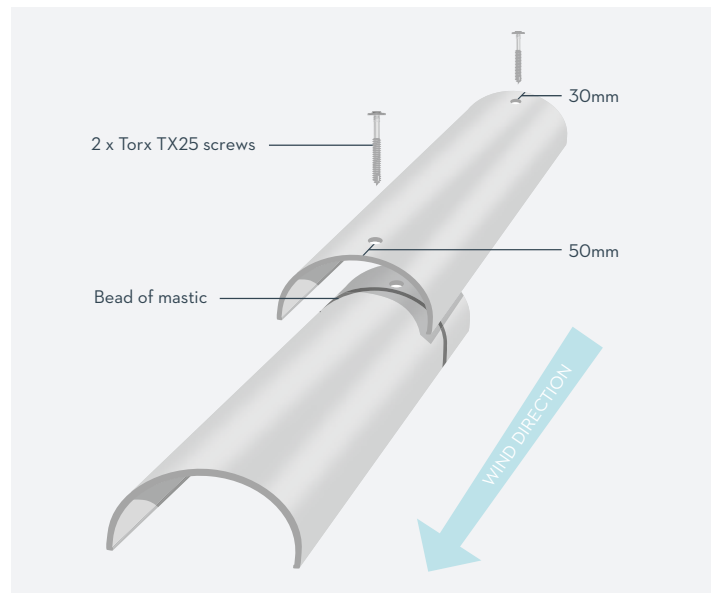

Half round/conic ridges

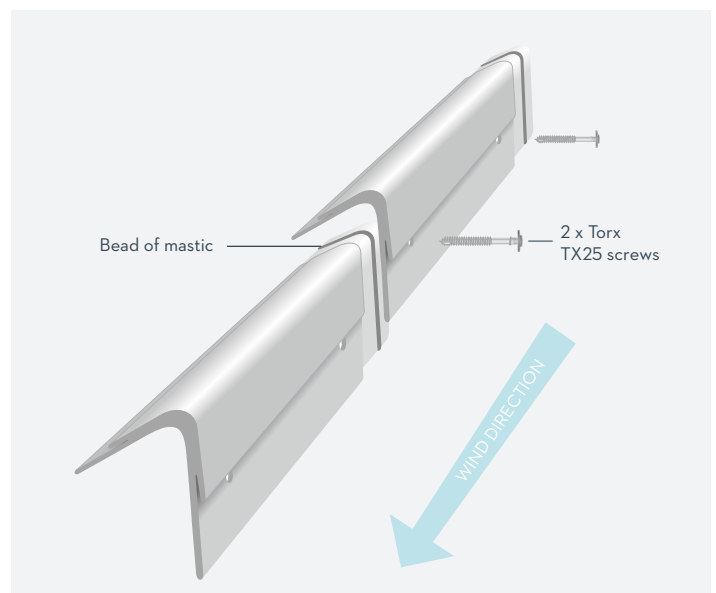

Continuously ventilated monopitch ridge

Fibre cement ridge/hip covering product range - Dimensions

Profile	Joint	Roof pitch	Ridge angle	Cover length (mm)	Wing (mm)	Cover width (diameter)	Block end depth (mm)
Universal							
	Spigot	25° to 40°	106°	600	175	252	n/a
End cap	Socket	25° to 40°	106°	600	175	252	200
End cap	Spigot	25° to 40°	106°	600	175	252	200
Plain angle							
	Spigot + Socket	22.5°	135°	525	120	200	n/a
End cap	Socket	22.5°	135°	500	120	200	190
	Spigot + Socket	30°	120°	525	120	200	n/a
End cap	Socket	30°	120°	500	120	200	195
	Spigot + Socket	37.5°	105°	525	120	200	n/a
End cap	Socket	37.5°	105°	500	120	200	190
	Spigot + Socket	45°	90°	525	120	200	n/a
End cap	Socket	45°	90°	500	120	200	200
	Spigot + Socket	52.5°	75°	525	120	200	n/a
End cap	Socket	52.5°	75°	500	120	200	75
Large half round conic							
		Pitches up to 30°	120°	c.400	n/a	(230) 206	n/a
Small end cap		Pitches up to 30°	120°		n/a	190	211
Large end cap		Pitches up to 30°	120°		n/a	220	228
Baby conic							
				c.300	n/a	(120) 112	n/a

Continous Ventilated Ridge

Roof pitch degree	Ridge angle	Weight per unit	Length	Crate quantity	Air gap per unit
45	90°	3.24Kg	525mm	145pcs	5880mm ²
37.5	105°	3.24Kg	525mm	130pcs	5880mm ²
30	120°	3.24Kg	525mm	140pcs	5880mm ²
22.5	135°	3.24Kg	525mm	140pcs	5880mm ²
52.5*	75°	3.24Kg	525mm	300pcs	5880mm ²

Continous Ventilated Monopitch Ridge

Roof pitch degree	Ridge angle	Weight per unit	Length	Crate quantity	Air gap per unit
20-40	50°	4Kg	525mm	84pcs	5880mm ²



Battens

Minimum batten sizes as recommended in Table 3 of BS 5534: 2014 for use with fibre cement slates for roofing and vertical work:

Span(mm)	Batten size(mm)
Up to 450mm	38 x 25
Up to 600mm	50 x 25

To avoid splitting the batten, the maximum nail diameter should not exceed one tenth of the batten width. The ends of any batten should be fully supported and the length of any batten should not be less than 1.2m (except where this is unavoidable) and nailed to a maximum of 600mm centres. Where the roof is close-boarded, counter battens should be used down the slope in the roof on the line of the rafters. Counter battens should be of sufficient thickness to provide ventilation between the boarding and underlay.

The batten gauges for common laps are shown in tables 1 and 2.

Underlay

Suitable underlay should have a minimum standard to BS 747: 2000 Type 1F should be UV resistant, comply with the relevant clauses of BS 5534 and therefore meet all the test criteria stated in BS EN 13859-1 and/or should have a BBA Certificate. The underlay should be draped over the rafters, or fully supported on boarding or sheathing, should allow any moisture to drain and should extend over the tilting fillet, fascia board and into the eaves gutter.

Ventilation

The roof space and/or batten cavity must be ventilated in accordance with the latest version of BS 5250:2011. Annex H of BS 5250:2011 gives guidance on the application of design principles. Sections H.3.3 - H.6 detail various roof constructions. Fibre cement slates should be considered an impermeable external covering.

In cold roof construction the loft space must always be ventilated. If an LR "breather" underlay is used the batten space must be ventilated. In warm roof construction with an HR underlay a ventilated void between the insulation and the underlay must be provided. If an LR "breather" underlay is used the underlay must be laid on the insulation and the batten space above must be ventilated, in addition an AVCL (impermeable membrane) must be provided

between the insulation and the internal finish. The most effective way to achieve this is through eaves to ridge ventilation. Cembrit Ltd. dry fixed continuously ventilated fibre cement ridge complies with British Standard Codes of Practice and NHBC guidelines, providing an unobtrusive, secure ridge line.

Lead staining risk

Lead develops a lead carbonate patina which, if washed over slates by rain or other moisture, causes unsightly staining. To prevent this reaction marring the work, it is advisable to treat all lead including soakers and flashings, with patination oil before any rain occurs, and not later than the day the lead is fixed. Patination oil, which is readily available from builders' merchants, should be applied following the manufacturer's instructions.

Identification

A minimum of 25% of the slates are marked on the underside using the following format: B 0123 01 NT B 1 012 0123 CEMBRIT where the first character denotes the factory of origin; the second to fifth characters the shift number, 6th and 7th characters the year of production; NT denotes nonasbestos technology; 10th and 11th characters the production and paint line, 12th to 14th the day in the year when painted and the final 4 characters the time.

Typical specification

Roof to be covered with Westerland Slates, size 600mm x 300mm, colour ..., laid to a minimum head lap of ... mm. To be used with Cembrit slate vents, ridges and roof trims. An NBS specification is available either from our Technical Department or our website.

Accessories

A full range of accessories including fibre cement undercloak/soffit strip is available. Please contact our Technical Department or see our website for full details.

Supply

Cembrit Ltd's fibre cement Westerland slates are supplied directly to approved accounts, roofing contractors and builders merchants. Prices are available on request from Cembrit Ltd.



Fibre cement slate storage

It is advisable that any building products with a high cement content, such as fibre cement slates, are protected from damp. They should ideally be stored under cover, on level ground, raised on battens or the pallets on which they are delivered.

If the slates are to be stored outside for a several days the plastic wrappings should be removed, the slate stacks moved apart to allow free air movement between the stacks and the whole covered with a tarpaulin or similar cover.

When stored outside overnight the sides of the plastic wrappings should be split open to allow free air movement between the slate stacks. The slates should then be covered with a tarpaulin or similar cover.



Other Cembrit ranges

Glendyne natural slate

Best quality natural slate, guaranteed and with multiple international accreditations.

Popular on listed buildings and where Festiniog Welsh slate (which is no longer available) is specified.

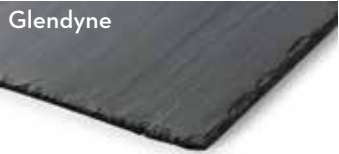

Building Boards

For specialist applications that cannot be met by commonly used gypsum or wood building boards such as sheathing, backing or partitioning.

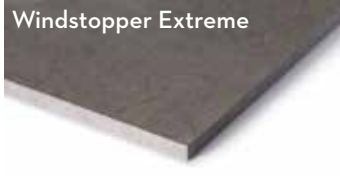

Other Cembrit ranges

Rainscreen cladding

Cembrit offers four compositions of rainscreen cladding in a total of 61 colour options to provide a beautiful and durable facade to any building.

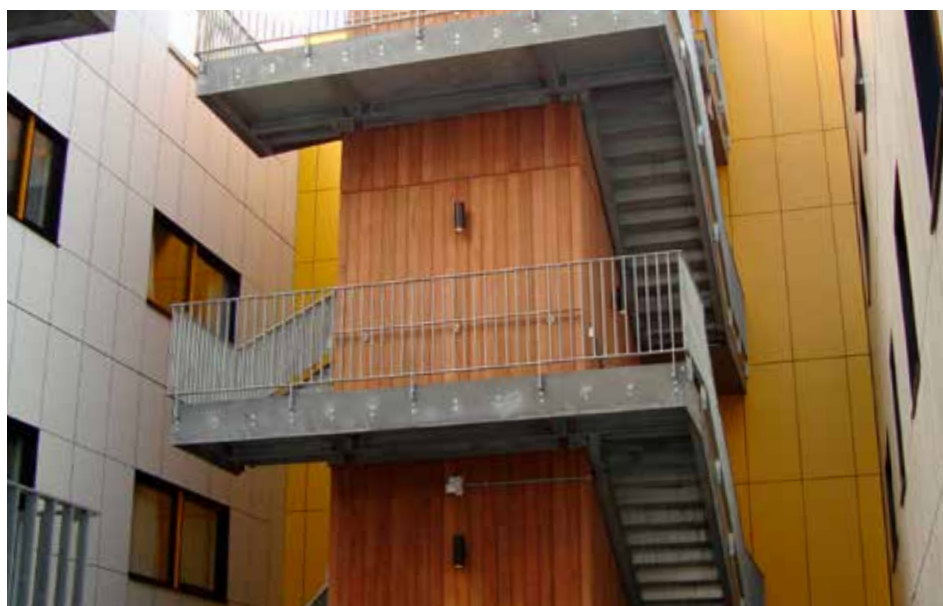
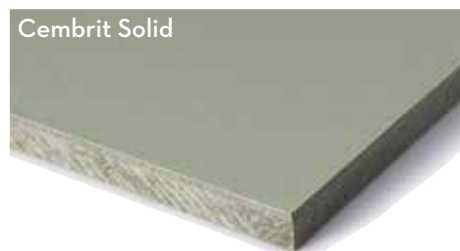

Corrugated sheet

Cembrit offers two corrugated sheet profiles to suit commercial, large agricultural, industrial and smaller equestrian or domestic applications.



Plank

Cembrit Plank is the ideal alternative to timber weatherboarding, but does not require preservative treatment and is not susceptible to fire. Smooth or textured options give you the choice of surface finish together with a colour to make your projects almost unique.



CEMBRIT

Building Better Days

Regional Depots

- 1 North T +44 (0)1924 890890
- 2 Wales T +44 (0)1446 773777
- 3 Central T +44 (0)1189 586217

sales@cembrit.co.uk

customerservices@cembrit.co.uk



Cembrit Ltd

First Floor in the WS Transport Building, Warehouse 145, Appleton Thorn, WA4 4TQ

info@cembrit.co.uk

www.cembrit.co.uk

Accreditations

Quality assurance

Cembrit fibre cement slates are manufactured in accordance with a quality assurance system to ISO 9001 and to the requirements of BS EN 492:2012.



Cembrit fibre cement slates are guaranteed for 30 years durability and 10 years colour stability. See our [website](#) for further information



Environmental impact

The EPD (environmental product declaration) for Cembrit fibre cement slates is available on request



Factory environmental management

Cembrit fibre cement slates are made in a factory which complies with BS EN ISO 14001:2015

Birmingham City Laboratories.

Cembrit fibre cement slates are approved for use on Birmingham City Council projects.

Product selection, specification and drawing design tools are available from RIBA or Cembrit websites

